

Enhancement Grant Recommendation

LCTC Building Trades

September 28, 2016

Unique Original Door Machine

Sealed bids for a Unique Original Door Machine were submitted in September 2016.

Stiles	\$28,950.00
Unique Machine & Tool Co.	\$28,950.00

Our recommendation is to accept the bid from **Stiles** based off recommendation from other building trades instructors. Building Trades was approved through **Enhancement Grant** for a total cost of \$29,000 for a Unique Door panel system. The District will be reimbursed at 75%.

Wide Belt Sander

Sealed bids for a wide belt sander were submitted in September 2016.

Laguna Tools	\$24,827.60
SW Mach	no bid provided

Our recommendation is to accept the bid from **Laguna**. Building Trades was approved through **Enhancement Grant** for a total cost of \$25,500 for a wide belt sander. The District will be reimbursed at 75%.



3965 44th Street SE
Grand Rapids, MI 49512
p 616.698.7500
f 616.698.9411
www.stilesmachinery.com

proposal

PREPARED FOR: **CAMDENTON SCHOOL
79 TRAIL RIDGE LANE
CAMDENTON, MO 65020**

ATTENTION: **MR. RYAN BEARDEN
573-346-9213 X
RBEARDEN@CAMDENTONSCHOOLS.ORG**

PROPOSAL: **EE-8500**

PROPOSAL DATE: **AUGUST 18, 2016**

SALES REPRESENTATIVE: **MR. STEVE KULLBERG
STILES MACHINERY INC.
586-764-2906**

EQUIPMENT: **UNIQUE
MODEL 250GT2**

CONDITION: **NEW**

Unique Original Door Machine Model 250GT2



Machine Features

- One Piece Welded Frame is precision machined
- Variable Speed Direct Drive 10 H.P. Shaper Motor
- 5" of vertical stack height capable of stacking up to three cutters
- Three Position Turret for quick change over between profiles
- Highly visible guards, protective clamp bar & poly-carbonate shield keep the operator protected
- Free Floating table allows for climb and conventional cutting to achieve best possible finish
- X axis movement of table guided by hardened Thomson shafts with linear bearings
- Y axis movement is guided by THK Rails & reciprocating ball bearings
- Two position pneumatic stop system positions automatically when cutters are selected
- Positioning scale allows for accurate centering of arched panel & rail
- 2" Maximum arch height, 55" maximum rail length
- One 998800 Template Included
- One Set of Tooling Included. Set includes Unique 410 cope/rail cutters and 460 panel cutter w/ back cut
- Includes 12 additional spare carbide inserts for the raised panel, cope and rail

Technical Specifications

Motor	10 HP, Direct Drive, 220 V, 3 PH Motor, 30A standard
Stacked spindle	Stacking capacity 5" or 8", 1-1/4" Diameter standard
Compressed air requirements	100 PSI, 1.5 CFM
Dust collection	One 5" dust port, 1,000 CFM
Machine weight	1,800 lbs
Work height	36"
Machine footprint	130" Width x 40" Depth
Maximum arch width	24"
Maximum straight cut length	55" for rails & 50" panel
Maximum arch height	2" or Custom up to 3-7/8"
Maximum material thickness	1" or optional 2-1/2" capacity
Maximum material width	1-1/2" plus the depth of cut

Price

Total price of above machine **\$ 28,950.00**

Includes freight

Price quoted excludes installation and all state and local taxes.

Terms of Payment (Subject to Credit Approval)

50% Deposit
Balance Due prior to shipping

Delivery

Shipment from the factory is approximately four (4) to six (6) weeks after receipt of official order with down payment and clarification of all technical details.

Machine Layout

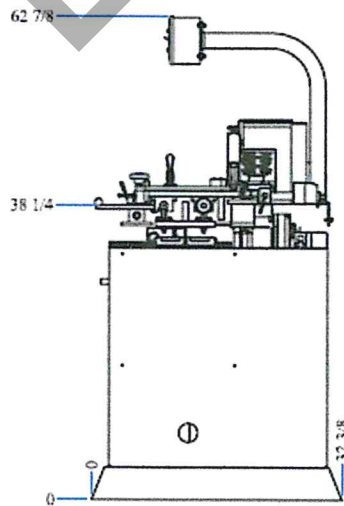
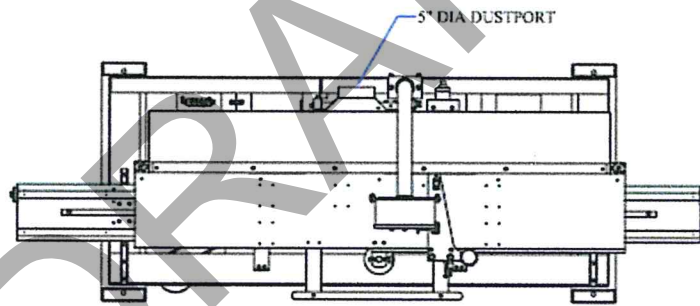
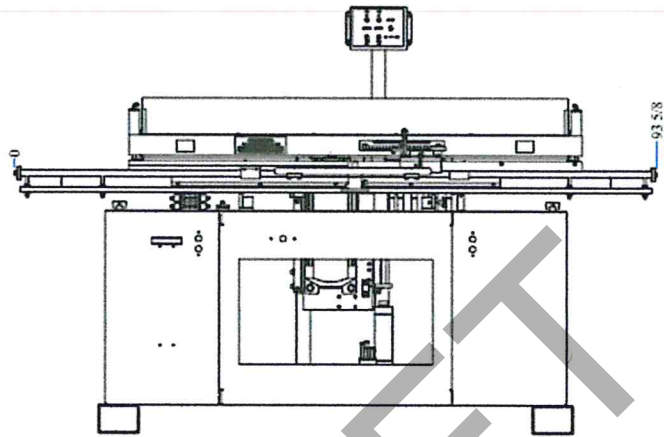

Machine Layout Including Tooling

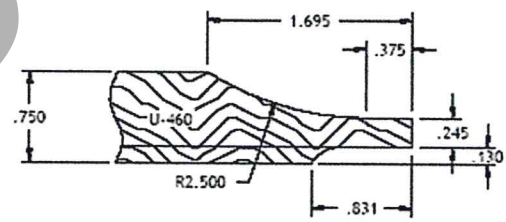
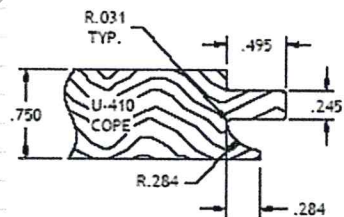
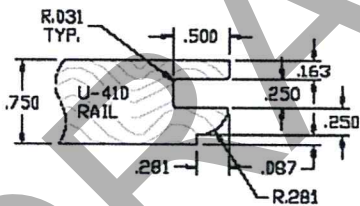
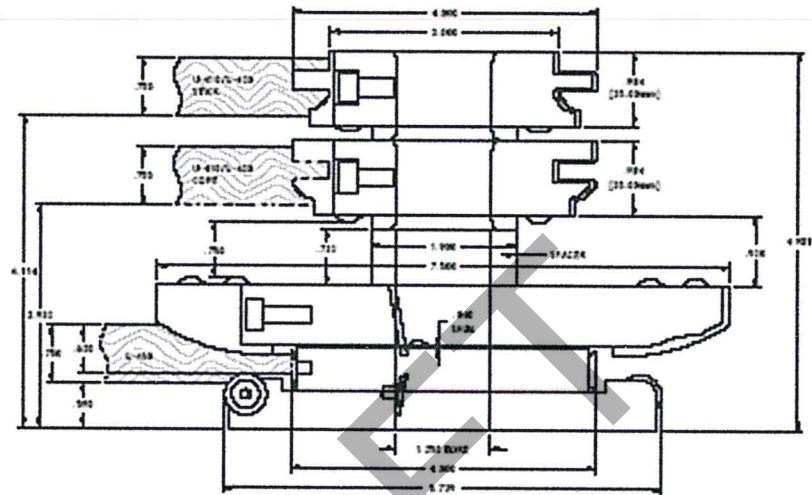

Machine Layout with XS Option Including Tooling

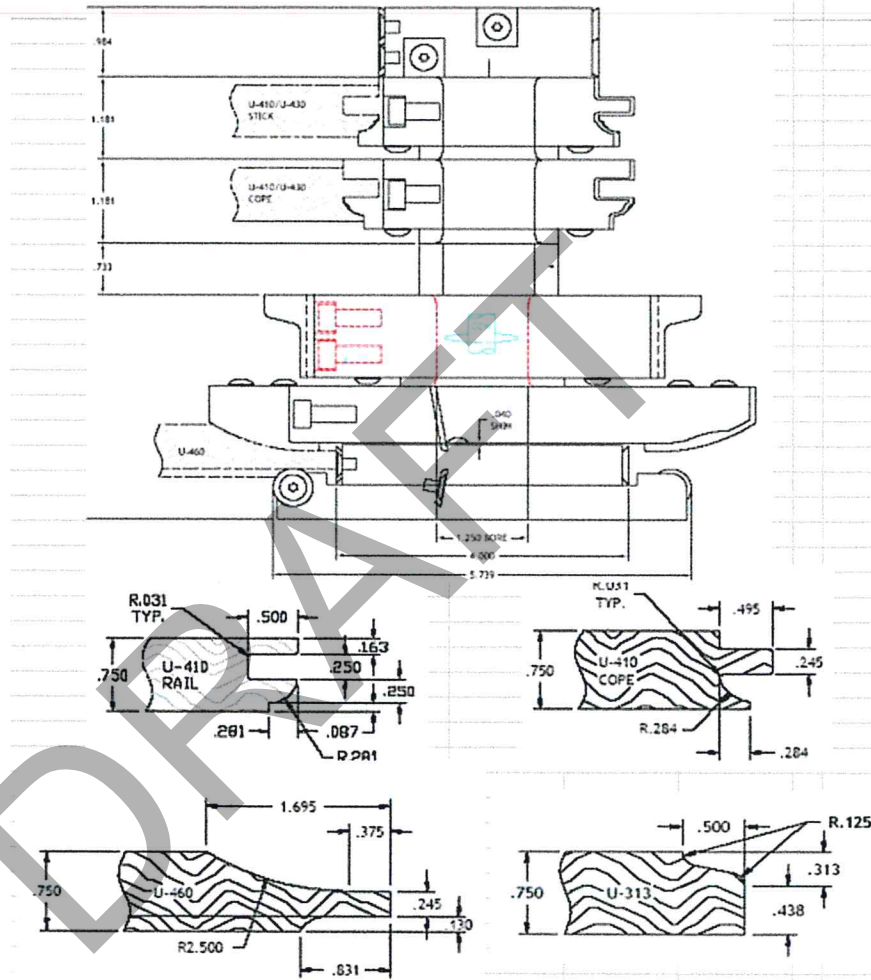

Machine 250 Templates

<u>1 1/8" Rise Cathedral Templates</u>			<u>Price</u>	<u>Qty.</u>	<u>Sub-Total</u>
998800	3", 4", 5", 6"		\$439.00	1	Included
998812	7", 8", 9", 10"		\$439.00	0	\$0.00
998900	11", 12", 13", 14"		\$439.00	0	\$0.00
<u>2" Rise Cathedral Templates</u>					
999802	3", 4", 5", 6"		\$439.00	0	\$0.00
100009	7", 8", 9", 10"		\$439.00	0	\$0.00
100010	11", 12", 13", 14"		\$439.00	0	\$0.00
		Size is: Radius of Arch			
<u>1 1/8" Rise Eyebrow Templates</u>					
998810	4", 5", 6", 7"		\$439.00	0	\$0.00
998820	8", 9", 10", 11"		\$439.00	0	\$0.00
998830	12", 13", 14", 15"		\$439.00	0	\$0.00
998840	16", 17", 18", 19"		\$439.00	0	\$0.00
<u>2" Rise Eyebrow Templates</u>					
100017	8", 9", 10", 11"		\$439.00	0	\$0.00
100018	12", 13", 14", 15"		\$439.00	0	\$0.00
100019	16", 17", 18", 19"		\$439.00	0	\$0.00
		Size is: Panel Width			
<u>1 1/8" Rise Cathedral Templates</u>					
998860	2", 3", 4", 5"		\$439.00	0	\$0.00
998870	6", 7", 8", 9"		\$439.00	0	\$0.00
100032	10", 11", 12", 13"		\$439.00	0	\$0.00
<u>2" Rise Cathedral Templates</u>					
100020	2", 3", 4", 5"		\$439.00	0	\$0.00
100021	6", 7", 8", 9"		\$439.00	0	\$0.00
100022	10", 11", 12", 13"		\$439.00	0	\$0.00
		Size is: Top Flat Area			
<u>Custom Templates</u>			\$795.00	0	\$0.00

Stiles Machinery Leasing Option

Stiles Machinery offers a variety of flexible financing options to meet your needs. Contact your sales representative for a detailed leasing quote.

Tooling

Tooling for the proposed machine is not supplied in the price quoted, unless otherwise stated. Stiles Machinery will provide a quotation for tooling upon receiving written documentation from customer stating their tooling application requirements. Any tooling requiring special application (i.e. profiles, grooves, cope, tenons, etc.) will require detailed drawings and/or samples to accompany the request.

Tooling ordered from any source other than Stiles Machinery Inc. will release Stiles Machinery of any responsibility for the performance of the machine functions dependent upon tooling.

Service and Parts

Stiles Machinery has made the most significant parts and service commitment in the industry. This commitment includes in excess of \$40 million on hand parts inventory available 24 hours/7 days a week/365 days a year. There is never an hour of any day that you cannot reach us for assistance. Your investment is further enhanced by a large, yet nimble service contingent consisting of approximately 100 Field Service Representatives working from five regional service centers available for quick dispatch and short travel times

Terms & Conditions

All equipment listed is offered subject to our Standard Terms and Conditions of Sale. The equipment is wired according to UL standards and may not conform to local codes in your area. If local regulations require inspection, the cost of the inspection and any modification(s) to the equipment is the responsibility of Buyer. Terms of payment offered herewith, or any terms agreed upon, are subject to proper credit approval. Due to fluctuations in currency exchange rates and freight costs, all prices are subject to confirmation or revision at time of order.

Unless otherwise stated, the price quoted is to be understood for delivery F.O.B. Port of Entry, U.S. Customs duty paid. Price of additional equipment, if any, valid only when installed at the factory during construction of the machine, and/or shipped with original machine. Technical description and data subject to change or modifications without notice. Our offers are contingent upon strikes, accidents to machinery by carriers, or any other cause beyond our control.

Unless specifically stated otherwise within the terms of this proposal, Stiles has no responsibility for staging, alignment or any other preparation of parts, panels or other materials fed into or otherwise introduced into the equipment covered by this proposal or for any unloading, stacking, routing, storing or any other disposition of parts, panels or other materials exiting such equipment.

This offer is valid for thirty (30) days.

STANDARD TERMS AND CONDITIONS OF SALE

The foregoing agreement by Stiles Machinery Inc. ("Seller") is subject to the following terms and conditions:

1. Acceptance

This agreement by Seller is subject to assent by the customer ("Buyer") to all terms herein to which Buyer has previously objected (if any), or which materially alter any terms proposed by Buyer (if any) covering the subject matter of this agreement. Buyer's acceptance of any part of the goods sold hereunder, any payment by Buyer for such goods, or any other form of acceptance by Buyer, shall constitute Buyer's acceptance of all terms and conditions herein. Descriptions, specifications, information and other data concerning Seller's products contained in Seller's catalogs, circulars, advertisements, price lists, or similar promotional materials or representations or statements thereof made by Seller's representatives or sales agents are the Seller's estimates and approximations only, and shall not be binding except as and to the extent expressly agreed to by Seller. Seller objects to any terms and conditions proposed by Buyer which vary the terms hereof. Buyer acknowledges that these terms and conditions shall continue to be binding on Buyer regardless of any type of financing utilized by Buyer and/or any assignment of this agreement by Buyer. Buyer may only assign this agreement with Seller's written consent. Unless specifically provided otherwise within the terms of this agreement, seller has no responsibility for staging, alignment or any other preparation of parts, panels or other material fed into or otherwise introduced into the equipment covered by this agreement, or for any unloading, stacking, routing, storing or other disposition of parts, panels or other materials exiting such equipment.

2. Price Adjustment

Prices are based upon material, production, and manufacturing costs as of the date hereof and upon duty, surcharge, tariff and similar import or export charges and currency exchange rates in effect on the date hereof. Should there be changes adverse to Seller in such prices, charges or rates occur, the Seller reserves the right to adjust prices accordingly. Seller's quotations are not binding upon Seller unless expressly stated as such in writing.

3. Delivery, Shipment, Security Interest, Risk of Loss, and Claims

Delivery of goods covered hereby shall be F.O.B. at the port of entry nearest Buyer unless otherwise specified by Seller. Seller may, at its option, ship all of the goods covered herewith at one time or in portions from time to time. Seller will attempt to ship goods for delivery on or about the times stated on the face hereof, although time shall not be of the essence in this contract. In the absence of instructions from Buyer, Seller shall have absolute discretion as to mode and routing of shipment. Until Buyer has paid in full for all products sold, Buyer grants to Seller a security interest in all such products and to the proceeds thereof. Buyer authorizes Seller to execute or authenticate, or at Seller's option, Buyer shall execute and deliver, any financing statements or other documents that Seller may reasonably require for the perfection of such security interest and Buyer hereby authorizes Seller to do all other acts reasonably necessary for the establishment, perfection, preservation, and enforcement of its security interest. Risk of loss of the goods shall pass to Buyer upon identification of the goods to the contract. Buyer shall have all responsibility for and expense of preparing and filing claims against carriers for loss or damage to goods in transit.

4. Force Majeure

Seller shall have no liability for any non-performance or delay in performance caused by circumstances beyond Seller's control, including, but not limited to, acts of God, fire, flood, war, government action, accident, labor trouble or shortage, inability to obtain material, equipment or transportation, or failure of Seller's suppliers to furnish the goods.

5. Taxes

Buyer shall pay all privilege, occupation, personal property, sales, excise, use and other taxes applicable to the sale, purchase, storage, erection, use or ownership of the goods covered hereby, regardless of whether such taxes are invoiced by Seller.

6. Installation, Setting Up and Starting Goods

Unless otherwise agreed, prices do not include product erection or installation which shall be Buyer's responsibility and expense. Buyer may obtain erection or installation service and assistance from the Seller pursuant to a separately negotiated agreement, provided however, that nothing in this agreement shall obligate Seller to enter into any such agreement with Buyer except upon terms and conditions acceptable to Seller. The limited warranty as provided for in paragraph 9 shall apply only to products erected or installed by Seller or under Seller's supervision, or by some person or organization expressly approved and authorized in writing by Seller to perform such erection or installation. In the event any product is not thus erected or installed, this limited warranty shall terminate immediately upon erection or installation or expiration of Buyer's 10-day inspection period as provided for in paragraph 11. The average cost of meals for Internal Revenue reporting is .19% of the cost of the goods. Seller accepts no responsibility for material and equipment or for the acts of persons furnished by Buyer.

7. Payment Terms

Unless otherwise agreed, the net amount for products purchased shall be due and payable by Buyer immediately upon receipt of Seller's invoice. Invoices not paid within thirty (30) days after the date of Seller's invoice will be subject to carrying charges. Carrying charges shall accrue in the amount of one and one half percent (1 - 1/2%) per month (18% per annum) on any overdue unpaid balance. Seller's invoice shall constitute an "evidence of indebtedness" as that term is related to the recovery of attorney's fees. Buyer shall reimburse Seller for the costs of collection, including reasonable attorney's fees of any overdue amount owed by Buyer to Seller and such collection costs shall be added to Buyer's indebtedness subject to the aforementioned carrying charges. If, in Seller's opinion, Buyer's financial condition at any time does not justify continuance of the production or shipment on the terms of payment herein specified, Seller may require full or partial payment in advance. All payments shall not be deemed to have been made until so received by Seller. Buyer shall have no right and waives any right to set off, offset or recoup any debts or liabilities of Seller to Buyer against amounts deposited with Seller or due Seller for the purchase of goods covered hereby.

8. No Liability to Third Persons

Seller shall in no way be liable to Buyer for any claim or action by any third person arising out of or alleged to arise out of the delivery of goods covered hereby or out of the presence of Seller's employees on Buyer's premises in connection with this agreement, or out of the use, by Buyer or third persons, of the goods covered hereby. "Third persons" shall include, without limitation, employees of both Buyer and Seller as well as all third persons not connected with Buyer or Seller.

9. Remedies of Buyer and Limitation of Warranties

Seller warrants that the goods sold hereunder shall be free from defects in materials and manufacture at the time of delivery to Buyer. Seller may, at its option, repair or replace any defect, or pay the reasonable cost thereof, for any such defects notice of which is given to Seller within thirty (30) days after discovery of such defect by Buyer, but not later than one (1) year after delivery of the goods to Buyer, except that notices for defects relating to motors, bearings, switches, contactors, relays, electronic components, air controls or air switches must be received within one hundred eighty (180) days of delivery of goods to Buyer. Seller shall have no obligation to remedy any defect except upon delivery of the defective part or parts to Seller at Seller's office in Grand Rapids, Michigan. The repair, replacement, or payment in the manner described above shall be the exclusive remedy of Buyer for breach of Seller's warranty. *Seller disclaims all other warranties whatsoever, express or implied, including all warranties of merchantability and fitness for a particular purpose. In no event shall Seller be liable for any consequential, incidental, special or indirect damages whatsoever (including without limitation personal injury, property damage, lost profits or other economic injury) even if Seller has been advised of the possibility of such damages. Buyer shall have no right of rejection or revocation of acceptance against Seller for any part or all of the goods covered hereby.* Normal wear, tear, and deterioration during use, including but not limited to such items as light bulbs, belts, synthetic material and fuses, shall not constitute a defect in material or manufacture under this limited warranty. The one (1) year limited warranty is based on Buyer's business consisting of a single shift eight hour per day operation. In no event is Seller liable for any damages or loss attributable to incorrect use or abuse of the goods, including but not limited to, inadequate or improper maintenance or unauthorized alteration. The foregoing warranty of Seller shall not limit Buyers' recourse against a manufacturer of goods sold hereunder for any warranty extended by such manufacturer. The warranty of any manufacturer or other third party shall not be deemed to be the warranty of Seller.

10. Compliance with Laws

Unless otherwise expressly agreed in writing signed by Seller and Buyer, Seller shall not be liable to Buyer for, and Buyer agrees to indemnify and defend and hold Seller harmless from, any liability arising or alleged to arise out of, any failure of the goods covered hereby to conform to any federal, state, or local law, order, regulation, or standard. The equipment is wired according to UL standards and may not conform to local codes in your area. If local regulations require inspection, the cost of the inspection and any modification(s) to the equipment is the responsibility of Buyer.

11. Statute of Limitations, Claims

No suit may be brought by Buyer for any breach by Seller or any other claim arising out of this contract after two (2) years from the date of delivery of the goods covered hereby. Within ten (10) business days after receipt by Buyer of products sold, Buyer must give written notice to Seller of any claim based upon the condition, quantity, or grade of the products sold or of any claimed nonconformity with Buyer's specifications, which notice must indicate the basis of Buyer's claim in detail. The failure of Buyer to comply with this paragraph 11 shall constitute irrevocable acceptance of the products sold to Buyer and bind Buyer to pay to Seller the full price of the goods or equipment.

12. Waiver of Claims or Defenses Against Secured Parties

Buyer agrees that it will not assert against any party having a security interest in any contract between Buyer and Seller, or in the inventory or accounts of Seller, or against any other assignee of any such contract, accounts, or inventory, any claim or defense which Buyer may have against Seller.

13. Safety Devices

In operating the products, Buyer shall use and require its employees and agents to use all safety devices and guards on the products and will otherwise employ safe operating procedures. Buyer shall not remove or modify any such devices, guards or warning signs. Should Buyer fail to observe such safety precautions, Buyer will indemnify and save Seller harmless from any risk, liability, or obligation to persons injured directly or indirectly in connection with the operation of the products. Buyer assumes full responsibility for damages to the products as a result of the use of qualities, grades, or quantities of materials which adversely affect the construction and operation of the products. Buyer further assumes full responsibility for training and to warn and protect all operating personnel and keep others away from any and all dangers in connection with the operation of the products. If any additional safety devices or guards are specified by Buyer, or by local laws/regulations, these safety devices or guards must be identified by Buyer and Seller will then provide a quotation.

14. Cancellation

An order once placed with and accepted by Seller can be cancelled by Buyer only with the written consent of Seller and upon the terms that will indemnify Seller against any loss.

15. Governing Law, Venue, Service of Process

This contract shall be deemed to have been made in the State of Michigan, and any action arising out of it shall be governed by the law of the State of Michigan. Any action arising out of this contract may be brought only in a state or federal court sitting in the County of Kent, State of Michigan. Buyer consents that such courts shall have personal jurisdiction over Buyer with respect to any such action.

16. Reservation of Rights

No failure of Seller to insist upon or compel compliance by Buyer with any of the terms, provisions, or conditions hereof shall be construed as a waiver by Seller of its right to insist upon compliance therewith in the future.

17. Complete Agreements Modification

The provisions hereof are intended as a complete and exclusive statement of the terms of the agreement between Seller and Buyer. This agreement may not be modified, rescinded, or cancelled, and no waiver by Seller of any claim or right hereunder shall be effective, except by writing signed by an officer of Seller.

UNIQUE MACHINE & TOOL CO.

Quote Number: 138258182
Sales Order Number: na
Date: 18-Aug-2016
Valid Through: 30-Sep-2016

Proposal For:

Ryan Bearden
Camdenton School
79 Trail Ridge Lane
Camdenton, MO

rbearden@camdentonschools.org

P: 573-346-9213

C: 573-280-8484

Txt or Email

Prepared By: JLL

Unique Contact

sales

Unique Machine & Tool Co.

sales@uniquemachine.com

Work: (602) 470-1911

Version 26.1D

4232 E. Magnolia St., Phoenix, Arizona 85034 U.S.A. Ph: (602) 470-1911 Fax: (602) 470-1916

Website: www.uniquemachine.com E-mail: sales@uniquemachine.com

4232 E. MAGNOLIA ST.
 Phoenix, AZ 85034
 Phone: (602) 470-1911
 Fax: (602) 470-1916
 Email: sales@uniquemachine.com

UNIQUE MACHINE & TOOL CO.

Version 26.1D
 Quotation: 138258182
 Sales Order: na
 *Date: 8/18/2016
 *Valid through: 9/30/2016
 Quoted by: sales

*Customer: Ryan Bearden
 Camdenton School

Ship To: 79 Trail Ridge Lane
 Camdenton, MO

Description	Price	Qty.	Sub-total
Model 250GT2 Original Door Machine	\$28,950.00	1	\$28,950.00

- One Piece Welded Frame is precision machined
- Variable Speed Direct Drive 10 H.P. Shaper Motor
- 5" of vertical stack height capable of stacking up to three cutters
- Three Position Turret for quick change over between profiles
- Highly visible guards, protective clamp bar & poly-carbonate shield keep the operator protected
- Free Floating table allows for climb and conventional cutting to achieve best possible finish
- X axis movement of table guided by hardened Thomson shafts with linear bearings
- Y axis movement is guided by THK Rails & reciprocating ball bearings
- Two position pneumatic stop system positions automatically when cutters are selected
- Positioning scale allows for accurate centering of arched panel & rail
- 2" Maximum arch height, 55" maximum rail length
- One 998800 Template Included
- One Set of Tooling Included. Set includes Unique 410 cope/rail cutters and 460 panel cutter w/ back cut

Standard Options

XS Option <i>Includes extended 8" spindle. *U-313 Edge Detail, Arch Hogging Cutter. 5 Position quick-change turret stop & heavy duty stop system that allows for additional cutters.</i>	\$4,950.00	0	\$0.00
<i>*Add Shaker tools instead</i>	\$890.00	0	\$0.00
Additional Spare Carbide Inserts (Raised Panel)	\$35.00 FREE	12	\$0.00
Additional Spare Carbide Inserts (Cope)	\$35.00 FREE	12	\$0.00
Additional Spare Carbide Inserts (Rail)	\$35.00 FREE	12	\$0.00
440/480 Volt Electric's	\$995.00	0	\$0.00
Additional Interchangeable THREE position Turret	\$235.00	0	\$0.00
Extended Clamp Cylinders (allows for 2 1/4" material)	\$1,550.00	0	\$0.00
UL Listed Control Panel <i>Underwriters Laboratories Inc. standard's are not considered on stock machines. UL requirements are determined on a regional basis and the necessity of UL specifications are the responsibility of the customer. The machine can be configured to meet UL specifications at time of purchase only, for an additional charge.</i>	\$1,990.00	0	\$0.00
Free Freight from Phoenix to Camdenton			\$0.00

Freight: F.O.B. Phoenix, AZ (Ship L.T.L. crated dim. 62" H x 97" L X 47" W. 1800 LBS)	Sub-total	\$28,950.00
*Terms: 50% Down, 50% Prior to ship	Deposit 50%	-\$14,475.00
Shipment: 4-6 weeks. Subject to change please call factory prior to order placement	Bal. Due	\$14,475.00

Contract: Signing this contract confirms my acceptance of the proposal and that I have read, understand and agree to all the terms, conditions, and warranty terms.

Name: _____

Position: _____

Acceptance of Sales Order

Date _____

4232 E. Magnolia St., Phoenix, Arizona 85034 U.S.A. Ph: (602) 470-1911 Fax: (602) 470-1916

Website: www.uniquemachine.com E-mail: sales@uniquemachine.com

4232 E. MAGNOLIA ST.
Phoenix, AZ 85034
Phone: (602) 470-1911
Fax: (602) 470-1916
Email: sales@uniquemachine.com

UNIQUE MACHINE & TOOL CO.

Version 26.1D
Quotation: 138258182
Sales Order: na
*Date: 8/18/2016
*Valid through: 9/30/2016
Quoted by: sales

*Customer: Ryan Bearden
Camdenton School

Ship To: 79 Trail Ridge Lane
Camdenton, MO

Model 250GT2 Footprint

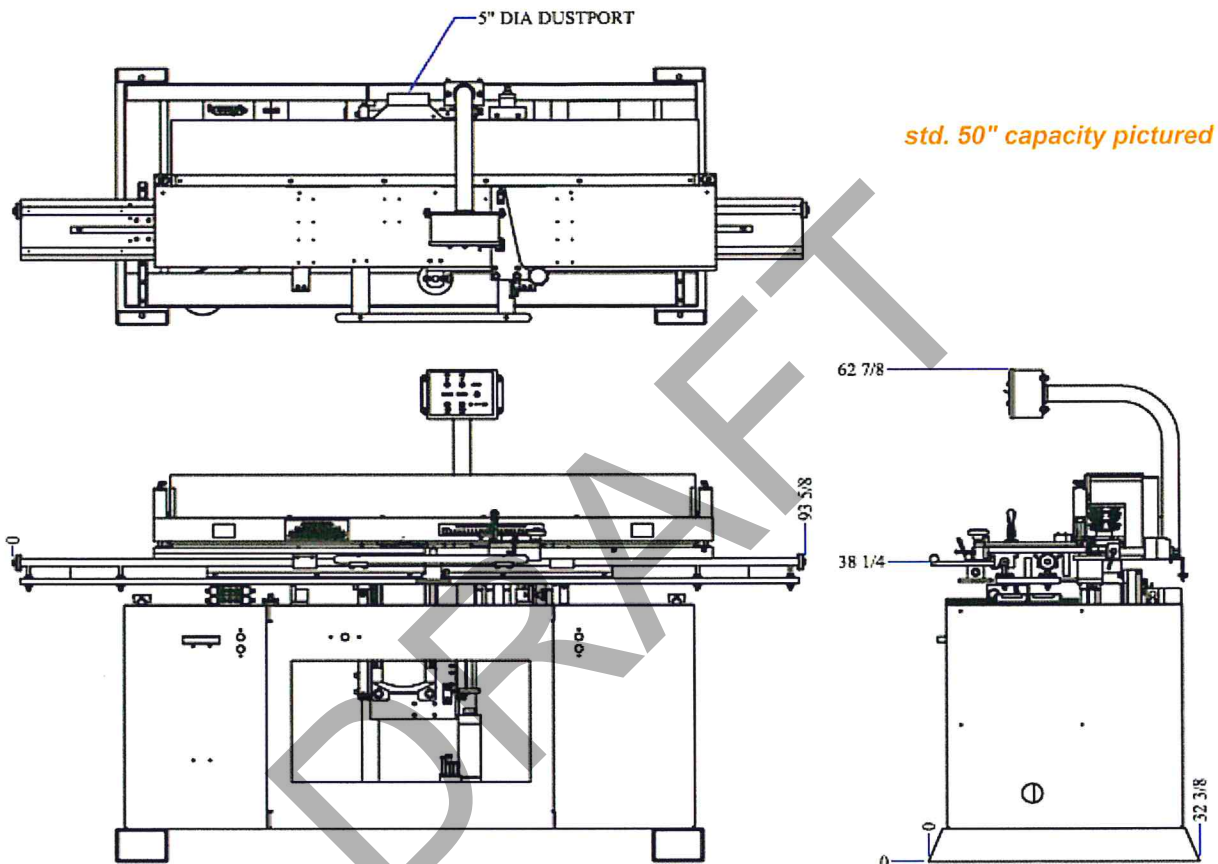

Specifications:

- Motor: 10 HP, Direct Drive, 220 V, 3 PH Motor, 30A standard
- Stacked spindle: Stacking capacity 5" or 8", 1-1/4" Diameter standard
- Compressed Air Requirements: 100 PSI, 1.5 CFM
- Dust Collection: One 5" dust port, 1,000 CFM
- Machine weight: 1,800 lbs
- Work height: 36"
- Machine footprint: 130" Width x 40" Depth
- Maximum arch width: 24"
- Maximum straight cut length: 55" for rails & 50" panel
- Maximum arch height: 2" or Custom up to 3-7/8"
- Maximum material thickness: 1" or an optional 2-1/2" capacity
- Minimum rail material width: 1-1/2" plus the depth of cut.

4232 E. Magnolia St., Phoenix, Arizona 85034 U.S.A. Ph: (602) 470-1911 Fax: (602) 470-1916
Website: www.uniquemachine.com E-mail: sales@uniquemachine.com

4232 E. MAGNOLIA ST.
Phoenix, AZ 85034
Phone: (602) 470-1911
Fax: (602) 470-1916
Email: sales@uniquemachine.com

UNIQUE MACHINE & TOOL CO.

Quotation: 138258182
Sales Order: na
*Date: 42600
*Valid through: 42643
Quoted by: sales

*Customer: Ryan Bearden
Camdenton School

Ship To: 79 Trail Ridge Lane
Camdenton, MO

Model 250GT2 Included Tooling

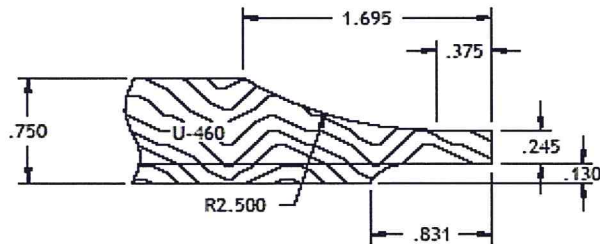
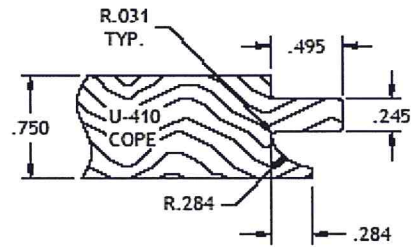
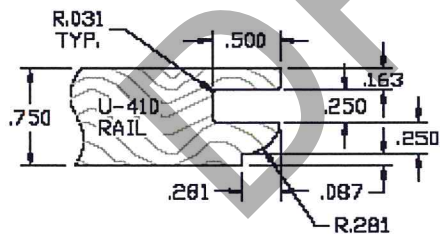
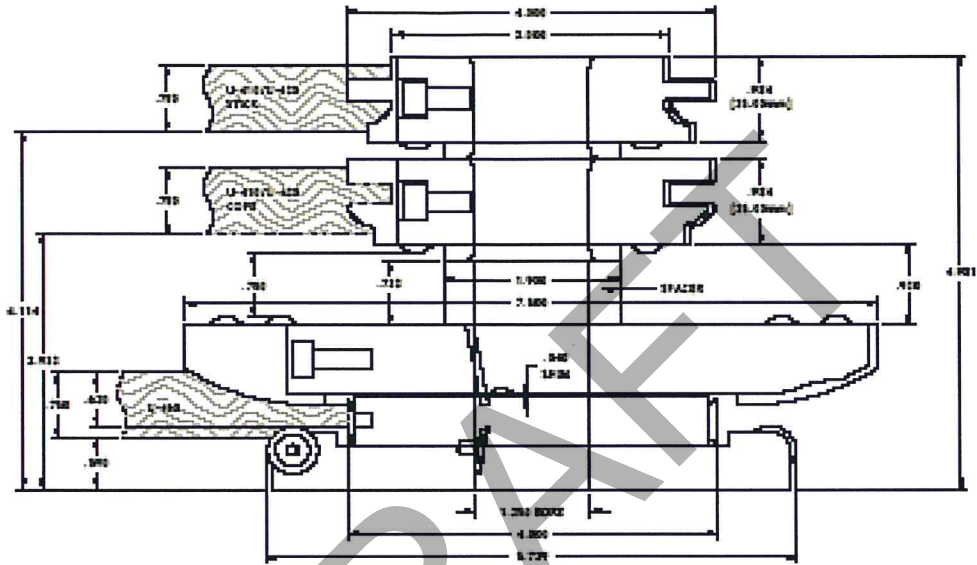

4232 E. Magnolia St., Phoenix, Arizona 85034 U.S.A. Ph: (602) 470-1911 Fax: (602) 470-1916
website: www.uniquemachine.com E-mail: sales@uniquemachine.com

4232 E. MAGNOLIA ST.
Phoenix, AZ 85034
Phone: (602) 470-1911
Fax: (602) 470-1916
Email: sales@uniquemachine.com

UNIQUE MACHINE & TOOL CO.

Quotation: 138258182
Sales Order: na
*Date: 42600
*Valid through: 42643
Quoted by: sales

*Customer: Ryan Bearden
Camdenton School

Ship To: 79 Trail Ridge Lane
Camdenton, MO

Model 250GT2 with XS Option Included Tooling

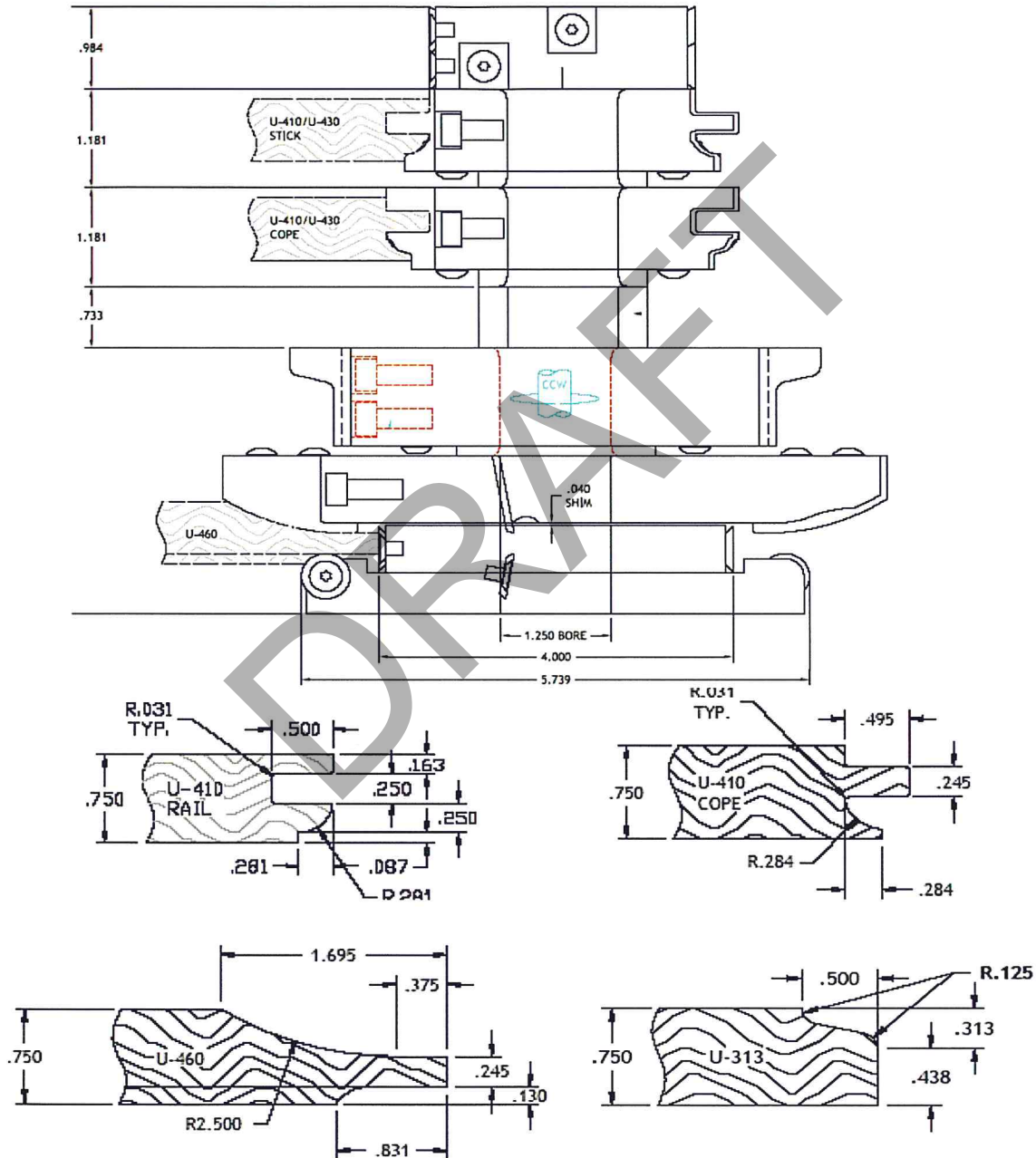

4232 E. Magnolia St., Phoenix, Arizona 85034 U.S.A. Ph: (602) 470-1911 Fax: (602) 470-1916
Website: www.uniquemachine.com E-mail: sales@uniquemachine.com

*must be filled in to be valid

4232 E. MAGNOLIA ST.
 Phoenix, AZ 85034
 Phone: (602) 470-1911
 Fax: (602) 470-1916
 Email: sales@uniquemachine.com

UNIQUE MACHINE & TOOL CO.

Version 26.1D

Quotation: 138258182
 Sales Order: na
 *Date: 8/18/2016
 *Valid through: 9/30/2016
 Quoted by: sales

*Customer: Ryan Bearden
 Camdenton School

Ship To: 79 Trail Ridge Lane
 Camdenton, MO

Model 250 Templates

		Price	Qty.	Sub-Total
1 1/8" Rise Cathedral Templates				
998800	3", 4", 5", 6"	\$439.00	1	Included
998812	7", 8", 9", 10"	\$439.00	0	\$0.00
998900	11", 12", 13", 14"	\$439.00	0	\$0.00
2" Rise Cathedral Templates				
999802	3", 4", 5", 6"	\$439.00	0	\$0.00
100009	7", 8", 9", 10"	\$439.00	0	\$0.00
100010	11", 12", 13", 14"	\$439.00	0	\$0.00
1 1/8" Rise Eyebrow Templates				
998810	4", 5", 6", 7"	\$439.00	0	\$0.00
998820	8", 9", 10", 11"	\$439.00	0	\$0.00
998830	12", 13", 14", 15"	\$439.00	0	\$0.00
998840	16", 17", 18", 19"	\$439.00	0	\$0.00
2" Rise Eyebrow Templates				
100017	8", 9", 10", 11"	\$439.00	0	\$0.00
100018	12", 13", 14", 15"	\$439.00	0	\$0.00
100019	16", 17", 18", 19"	\$439.00	0	\$0.00
1 1/8" Rise Cathedral Templates				
998860	2", 3", 4", 5"	\$439.00	0	\$0.00
998870	6", 7", 8", 9"	\$439.00	0	\$0.00
100032	10", 11", 12", 13"	\$439.00	0	\$0.00
2" Rise Cathedral Templates				
100020	2", 3", 4", 5"	\$439.00	0	\$0.00
100021	6", 7", 8", 9"	\$439.00	0	\$0.00
100022	10", 11", 12", 13"	\$439.00	0	\$0.00
Custom Templates		\$795.00	0	\$0.00

Freight: F.O.B. Phoenix, Arizona	Sub-total	\$0.00
*Terms: 50% Down, 50% Prior to ship	Deposit 50%	\$0.00
Shipment: 1-2 weeks. Subject to change please call factory prior to order placement	Bal. Due	\$0.00

Contract: Signing this contract confirms my acceptance of the proposal and that I have read, understand and agree to all the terms, conditions, and warranty terms.

Name: _____ Position: _____

Acceptance of Sales Order Date _____

4232 E. Magnolia St., Phoenix, Arizona 85034 U.S.A. Ph: (602) 470-1911 Fax: (602) 470-1916
 Website: www.uniquemachine.com E-mail: sales@uniquemachine.com

4232 E. MAGNOLIA ST.
 Phoenix, AZ 85034
 Phone: (602) 470-1911
 Fax: (602) 470-1916
 Email: sales@uniquemachine.com

UNIQUE MACHINE & TOOL CO.

Version 26.1D
 Quotation: 138258182
 Sales Order: na
 *Date: 8/18/2016
 *Valid through: 9/30/2016
 Quoted by: sales

Machines	Qty	Total
250GT2	1	\$28,950.00
Arch Templates		\$0.00
265BD Cope		\$0.00
265DD Cope		\$0.00
275		\$0.00
280/ClampTable		\$0.00
Spacer Inserter		
290 MDF Door		\$0.00
310 GT Cope		\$0.00
313 FJ Miter		\$0.00
313 GT		\$0.00
410 Shape		\$0.00
411 Shape-Sand		\$0.00
412 Shape-Sand		\$0.00
515 Line Drill		\$0.00
523 Line Drill		\$0.00
2681 CNC		\$0.00
2722M CNC		\$0.00
3411 CNC Bore		\$0.00
3450 Mort/Ten		\$0.00
4522 SS		\$0.00
4523 SS		\$0.00
4524 SS		\$0.00
71/73 Drill Tub		
79/80 FaceFrame		
Face Frame Pkg		\$0.00
Tooling Adtl		\$0.00
Totals		\$28,950.00

Unique Machine & Tool Co. Terms & Conditions of Sale:

The purchaser, broker, sales representative, customer, subsequent purchaser, user or end-user will be hereinafter referred to as the customer. By the signing of this order, the customer agrees to be bound contractually by all these terms and conditions in addition to those that may be contained in other applicable documents including but not limited to the written warranty certificate. General Terms and Conditions apply to all products unless specifically stated otherwise.

Warranty: One year for parts only, FOB Phoenix, AZ. Any applicable shipping expenses are not included (FOB - Unique, Phoenix, AZ), unless otherwise specifically stated. Applicable local, state, and/or federal taxes are not included and are the responsibility of the purchaser. Purchasers of Systems must be trained at the plant located in Phoenix, Arizona prior to shipment of their equipment. Purchaser agrees to sign off on the equipment certifying that the equipment meets their specifications at factory prior to shipment and installation. Normal technician travel and lodging expenses for training and installation are not included and are billed separately, unless otherwise specifically stated.

Factory Training: includes configuring customer files and settings within the limits of the standard software provided by Unique for downloading. Ethernet, RJ45, RS232, wireless, or network communication cables (to connect machine to your computer and/or network) are not included. Unique is not responsible for any Network or IT installation, training, or setup. This quotation, specifications, & pricing valid for only 30 DAYS. All Specifications are subject to update, upgrade, and/or revision without notice. It is the customer's sole responsibility to determine their power & voltage requirements. If Unique is unable to successfully install and train for this machine during the allotted time due to lack of preparedness of the end-user or any failure or inability of the end-user to provide adequate and unfettered access to the machine being installed, then additional days of installation/training must be purchased & re-scheduled for a later date at customer expense.

Installation: Purchaser shall agree to have all power, air, and exhaust at machine prior to the beginning of installation. Installation technician shall have unfettered access for the purpose of installation. Purchaser agrees to have available at all times during installation necessary man power and equipment to assist the installation technician. Purchaser further agrees to provide and have prepared the site and requirements of the most recent Site Preparation Confirmation Sign Off Sheet. If these conditions are not met, Unique Machine & Tool Co. will not be held liable for production downtime, payments due, or finance charges incurred.

Payment Terms: Installed Systems - 50% down with signed order (order will not be scheduled until receipt of down payment), 45% additional due at least 5 days prior to shipment. Final 5% due at install or net 10 days after scheduled installation, whichever comes first. Uninstalled Systems - 50% down with signed order (order will not be scheduled until receipt of down payment), 50% prior to shipping. If buyer fails to make the second progress payment in a timely manner, after being notified that the machine is ready to ship, then that non payment can result in a non-payment penalty of 1.5% per month.

Delivery: orders can be from stock / inventory, but normal standard delivery can be up to 6 weeks. Delivery of non-standard, custom, or multi-head machines is normally up to 12 weeks, and typically does not exceed 16 weeks. All delivery times are dependent upon backlog at the time we receive your deposit / order. Delivery times do not begin until the initial 50% deposit and a signed sales contract arrives at Unique.

Unique maintains first lien on the equipment & the title doesn't pass until final payment has been made for all Unique Machine & Tool Co. Products and purchaser agrees to insure equipment against all hazards while on their premises regardless of ownership of said goods. The title and risk of loss or damage for all other products shall pass to the purchaser when the goods are shipped from Unique. If your account payment status is not kept current & satisfactory, all tech support, software support, & warranty will be suspended.

Upon signing contract, customer cannot return products; a 20% cancellation fee will be incurred for cancellation of order. Unique does not warrant against, and shall not be held responsible for any economic loss, loss of production or materials, property damage, product liability, personal injury, or any other claim by purchaser, its agents, employees, insurance carriers, subrogates, successors, assigns, or third parties arising out of the use of the products except as expressly provided.

It is the customer's sole responsibility to assure the safe use, maintenance, and operation of the products & of all options, safety equipment, and additions. It is also the customer's sole responsibility to comply with all requirements or recommendations of the company, OSHA, and any other state or federal safety laws or regulations as they may pertain to the operation of the products. Purchaser agrees to hold harmless and to defend Unique Machine & Tool Co. against any action arising from the purchase and use of this or any other equipment.

This Contract & Unique's written warranty are non-transferable, and are in lieu of all other warranties expressed or implied, without limitation to implied warranties of merchantability or fitness for any particular purpose. This Agreement & the attachments, if any, represent the entire agreement & understanding of the parties, & supersede all prior & contemporaneous agreements & understandings, oral or written. Salespeople & distributors lack the authority to alter this agreement. Shipping damage and non functional cosmetics damage, are non warrantable. Customer accepts that due to the nature of the product some scuffs, dings, dents, scratches and other external imperfections are normal and acceptable.

Governing Law: This agreement shall be governed by and construed according to the laws of the State of Arizona. Venue for any dispute shall be in Phoenix, AZ. Force Majeure: Neither Unique Machine & Tool Co. nor Purchaser shall be liable for delays in performance due to causes beyond the control and without the fault or negligence of the party whose performance is affected, including, but not limited to, acts of God, labor disputes or the government. Force majeure shall not relieve purchaser's payment obligations.

Severability: In the event that any portion of this agreement is deemed to be unlawful, it is agreed that all other parts shall remain in full force and effect.

Payment Schedule

Down Payment	50%	\$14,475.00
Prior to Shipment	50%	\$14,475.00

Contract: Signing this contract confirms my acceptance of the proposal and that I have read, understand and agree to all the terms, conditions, and warranty terms.

Name: _____

Position: _____

Acceptance of Sales Order

Date _____

4232 E. Magnolia St., Phoenix, Arizona 85034 U.S.A. Ph: (602) 470-1911 Fax: (602) 470-1916

Website: www.uniquemachine.com E-mail: sales@uniquemachine.com

LAGUNA TOOLS Quote

T H R I V I N G O N I N N O V A T I O N

Laguna Alton Parkway
 2072 Alton Parkway
 Irvine CA 92606
 949 474 1200 or 800 234 1976
 www.lagunatools.com
 Tax ID # 93 1083116 93-1083116

Date 8/30/2016
 Quote # 32902

Expires 10/14/2016
 Sales Rep Gerald Goodman
 Ship Via Best Method
 Promise Date

Lake Career & Technical
 Center
 Jackie Jenkins Director
 43" WIDEBELT
 SANDER
 PO BOX 1409
 Camdenton MO 65020

Customer Details:

Lake Career & Technical Center
 Jackie Jenkins Director
 PO BOX 1409
 Camdenton MO 65020

Ship To

SANC

Quote Ship to:

Qua...	Item #	Description	Rate	Amount
1	MSANWB43...	Pro 43" X 2RK Widebelt Sander 25HP 3Ph 43" x 75" Belt	24,999.00	24,999.00
1	SP4375100	Accessory - Sander 43" x 75" Belt 100 Grit	160.00	160.00
1	SP4375120	Accessory - Sander 43" x 75" Belt 120 Grit	160.00	160.00
1	SP437580	Accessory - Sander 43" x 75" Belt 80 Grit	195.00	195.00
1	/CNC SHIPPI...	FLAT BED AIR RIDE SHIPPING REQUIRES A FORKLIFT AT TIME OF ARRIVAL	0.00	0.00
	10% Off Disc...		-10.00%	-2,551.40
1	Best Method	Best method of Shipping	1,865.00	1,865.00

Total \$24,827.60

This Sale Agreement is a legal contract between the Customer and Laguna Tools Inc., The Customer accepts this Sale Agreement by making a purchase and/or by placing an order. This Agreement will be governed by and construed in accordance with the substantive laws of California, notwithstanding any conflict of law principles. Defective merchandise must be returned with an authorized RMA (Return Merchandise Authorization)

DRAFT

← *Jay Jordan*